

► **FEATURES**

- Measures cell, strain gauge signal 0~1.0/~2.0/~4.0/~10.0/~20.0/~40.0mV/V
- Accuracy: $\pm 0.04\%$; Display range: -19999~29999
- Easily programmable via the front panel
- **Up to 2 relays available with latching and time delay programmable**
- Analogue output and RS 485 Modbus options
- **1 external control inputs for Reset, tare and hold functions**
- CE Approved

Note:- This product has many state of art functions. Please download our 'common functions' document from the customer portal for explanations

► **ORDER CODING**

DP3-SG-

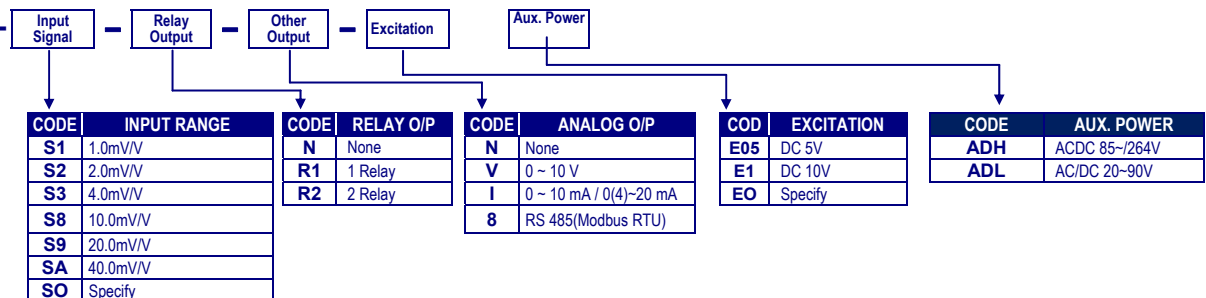
■ **TECHNICAL SPECIFICATIONS**

| Input | Measuring Range | Impedance | Excitation Voltage |
|------------|-----------------|---------------|-------------------------------|
| All Ranges | | $\geq 1M$ ohm | DC 5V, 30mA or DC 10, 30mA |

Calibration: Digital calibration by front key
A/D converter: 16 bits resolution
Accuracy: $\leq \pm 0.04\%$ of FS $\pm 1C$;
Sampling rate: 15 cycles/sec
Response time: ≤ 100 msec.(when AvG = "1") as standard

Input range: Input High and Low programmable
 Ai.Hi: Settable range: 0.00~100.00% of input range
 Ai.Lo: Settable range: 0.00~100.00% of input range

Display & Functions

LED: Numeric: 5 digit, 0.4"(10.0mm)H red high-brightness LEDs
 Relay output indication: 2 square red LEDs
 RS 485 communication: 1 square orange LEDs
 E.C.I. function indication: 1 square green LEDs
Display range: -19999~+29999;
Scaling function: Lo.SC: Low Scale; Settable range: -19999~+29999
 Hi.SC: High Scale; Settable range: -19999~+29999
Decimal point: Programmable from 0 / 0.0 / 0.00 / 0.000 / 0.0000
Over range indication: ovFL, when input is over 20% of input range Hi
Under range indication: -ovFL, when input is under 20% of input range Lo
Max / Mini recording: Maximum and Minimum value storage during power on.
Display functions: PV / Max(Mini) Hold / RS 485 programmable
Front key functions: Up key can be set to be a function as ECI.1
Low cut: Settable range: -19999~29999 counts
Digital fine adjust: Pv.Zro: Settable range: -19999~+29999
 Pv.SPn: Settable range: -19999~+29999

Reading Stability Function

Average: Settable range: 1~99 times
Moving average: Settable range: 1(None)~10 times
Digital Filter: Settable range: 0(None)/1~99 times

Control Functions

Control relay: 2 Relays FORM-C, 1A/230Vac, 3A/115V
Relay energized mode: Energized levels compare with set-points:
 Hi / Lo / Hi.HLd / Lo.HLd programmable
Energized by RS485 command of master: DO programmable
Energized functions: Start delay / Energized & De-energized delay / Hysteresis
 Energized Latch
Start band(Minimum level for Energizing): 0~9999counts
Start delay time: 0.00.0~9(Minutes):59.9(Second)
Energized delay time: 0.00.0~9(Minutes):59.9(Second)
De-energized delay time: 0.00.0~9(Minutes):59.9(Second)
Hysteresis: 0~5000 counts

External Control Inputs(ECI)

Input mode: 1 ECI points, Contact or open collect input, Level trigger
Functions: Relative PV(Tare) / PV Hold / Reset for Max or Mini. Hold / DI / Reset for Relay latching
Debounce time: Settable range 5 ~255 x 8m seconds

Analogue output(option)

Accuracy: $\leq \pm 0.1\%$ of F.S.;
Ripple: $\leq \pm 0.1\%$ of F.S.
Response time: ≤ 100 msec. (10~90% of input)
Isolation: AC 1.5 KV between input and output
Output range: Specify either Voltage or Current output
 Voltage: 0~5V / 0~10V / 1~5V programmable
 Current: 0~10mA / 0~20mA / 4~20mA programmable
Output capability: Voltage: 0~10V; $\geq 1000\Omega$;
 Current: 4(0)~20mA; $\leq 600\Omega$ max

Functions:

Ao.HS (output range high): Settable range: -19999~29999
Ao.LS (output range Low): Settable range: -19999~29999
Ao.LMt (output High Limit): 0.00~110.00% of output High
Ao.Zro: Settable range: -38011~+27524
Ao.SPn: Settable range: -38011~+27524

Digital fine adjust:

RS 485 communication(option)

Protocol: Modbus RTU mode
Baud rate: 1200/2400/4800/9600/19200/38400 programmable
Data bits: 8 bit
Parity: Even, odd or none (with 1 or 2 stop bit) programmable
Device no: 1 ~ 255 programmable
Remote display: to show the value from RS485 command of master
Distance: 1200M
Terminate resistor: 150Ω at last unit.

Electrical Safety

Dielectric strength: AC 1.5 KV for 1 min, Between Power / Input / Output / Case
Insulation resistance: ≥ 100M ohm at 500Vdc, Between Power / Input / Output
Isolation: Between Power / Input / Relay / E.C.I./ Analogue or RS485
EMC: EN 55011:2002; EN 61326:2003
Safety(LVD): EN 61010-1:2001

Environmental

Operating temp.: 0~60 °C
Operating humi.(%RH): 20~95 %RH, Non-condensing
Temp. coefficient: ≤100 PPM/°C
Storage temperature: -10~70 °C
Enclosure: Front panel: IEC 549 (IP54); Housing: IP20

Mechanical

Dimensions: 48mm(W) x 24mm(H) x 102mm(D)
Panel cutout: 45mm(W) x 22.5mm(H)
Case materiel: ABS fire-protection (UL 94V-0)
Mounting: Panel flush mounting
Terminal block: Plastic NYLON 66 (UL 94V-0)
 5A 300Vac, M2.0, 0.5~1.3mm²(22~16AWG)

Weight: About 110g

Power

Power supply: AC/DC 85~264V or AC/DC 20~90V
Excitation supply: DC 24V, 30mA maximum in standard
Power consumption: 4.5VA max.
Back up memory: By EEPROM

FRONT PANEL

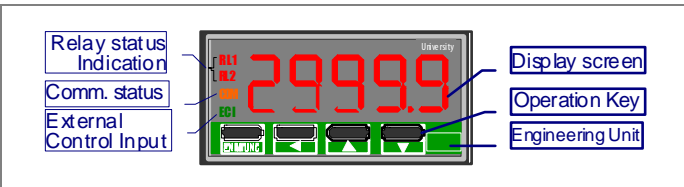

DIMENSIONS

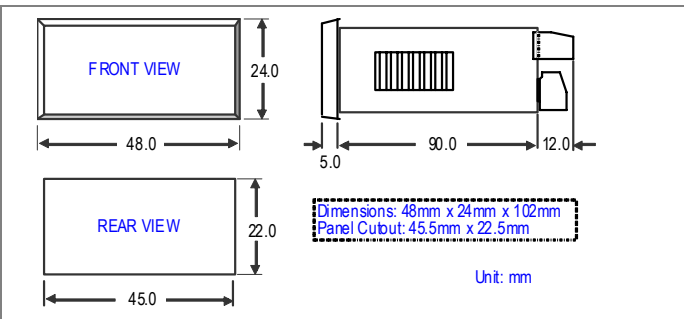

INSTALLATION

The meter should be installed in a location that does not exceed the maximum operating temperature and provides good air circulation.

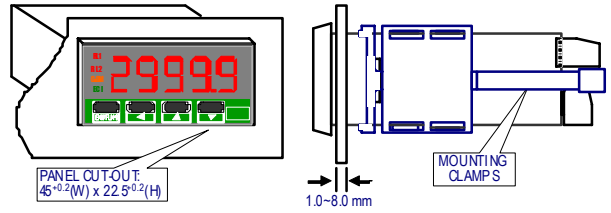

CONNECTION DIAGRAM

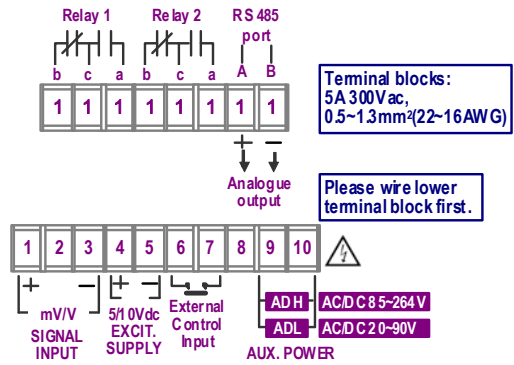

Please check the voltage of power supplied first, and then connect to the specified terminals. It is recommended that power supplied to the meter be protected by a fuse or circuit breaker.

Power Supply (Recommendation)

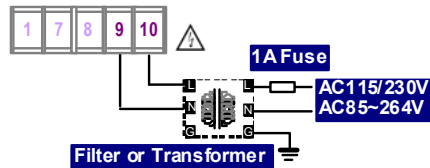

Load Cell connection

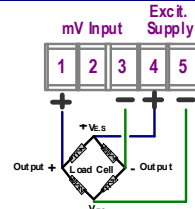

RS485 Communication Port

