

Introduction

The power quality meter HC 6030 is an ideal device to power monitoring in power quality when continuous monitoring to a power system is required.

The HC 6030 provides metering for current, voltage, real and reactive power, power energy, power factor, frequency energy demand and 8 TOU channels with tariff to power energy. 24 programmable setpoints and 3 assignable output relays allow control functions to be added for specific applications. This includes basic alarm on over / under current or voltage, unbalance, demand based load shedding, and capacitor power factor correction control.

More complex control is possible using the 8 switch inputs which also can be used for status such as breaker open / closed, or pulse counter to flow information or demand synchronized trigger and etc.

The provided measurement to main of AC power and auxiliary of 3 analog process inputs, 8 digital inputs, the HC 6030 may be used as a data gathering device for a plant automation system that integrates process, instrument and electrical requirements. All monitored values are available via two digital communication ports RS485 and RS232 running the ModBus® protocol. If analog values are required for direct interface to a PLC, and of the monitored values can be output to one of 4 isolated analog outputs and 2 pulse outputs. Process variables can be measured using 3 analog inputs. Other plant personnel can connect a front panel RS232 communication port to a PC for simultaneous access of information.

The quality of the power system is important with increasing use of electronic loads such as switching power or variable frequency drives. With the HC 6030 auxiliary input / output, any phase current / voltage can be displayed and the harmonic content calculated. By knowing the harmonic distribution, action can be taken to prevent overheated transformer, motors, capacitors, neutral wires and nuisance breaker trips. Redistribution of system loading can also be determined. Waveform and chart recorder printouts available from the HC 6030 assist in problem diagnosis.

Features

- Metering of distribution feeders, transformers, generators, capacitor banks and motors
- Medium and low voltage systems
- Commercial, industrial, utility
- Flexible control for demand load shedding, power factor, etc.
- Power quality analysis.
- A / W / Var / VA demand
- 8 digital inputs / pulse input totalizing
- 3 controlled relay outputs
- 3 analog process inputs
- 4 isolated analog outputs to a transducer function
- 2 pulse outputs based on KWH, KVarH, KVAH or AH
- 8 channels for time of use to power energy
- Load shedding
- Power factor control
- Event log
- Minimum / maximum logger
- Data trend logger
- Waveform capture / harmonic analysis through 31rd
- Triggered trace memory (Fault recording)
- Ports : RS232 front, RS485 rear
- ModBus® RTU protocol metering

Metering

Each voltage and current is sampled 64 times per cycle for 0.2% accuracy true RMS measured values.

- A1, A2, A3, A0, A_E
- Va, Vb, Vc, Vab, Vbc, Vca, V_{PE}, V_{LE}
- W, Var, VA, total & individual
- Hz & phase rotation sequence
- True PF crest & K factor
- WH, VarH, VAH, AH
- Demand : A, W, Var, VA

A keyboard and 3 illuminated VFD module each with 9 character display are used for field programming, setup monitoring values and status.

Setpoints to Alarms

Any of the assignable output relays may be used to trigger and alarm for specific applications.

Condition	Application
Over current	Motors / transformers
Under current	Pumps / compressors
Neutral current	Leakage / unbalance
Current unbalance	Motors
Over voltage	Equipment protection
Under voltage	Motors / load transfer
Phase sequence	Pumps / equipment
Over frequency	Generators
Under frequency	Load shedding
Power factor	Capacitor banks
Switch input	Process control

Communications

Integrate process, instrumentation and electrical requirements in a plant automation system by connecting HC 6030 meters together to a DCS or SCADA system. A PC running the HC 6030 can change system setpoints, monitor values, status and alarms. Continuous monitoring minimizes process downtime by immediately identifying potential problems due to faults or changes from growth.

- RS485 ModBus® 1,200 ~ 19,200 bps
- RTU SCADA system component
- Measure actual values
- Read status

- Issue control commands
- Load all setpoints from a file
- Change individual setpoints

The standard version the HC 6030 comes complete with a front RS232 port. The RS232 port can be used for data collection, printing reports or problem analysis without disturbing the main communication interface to rear RS485 port.

Upgrade to future expansion

Flash memory is used for firmware storage within the HC 6030. This allows future product upgrades to be loaded via the serial port.

Initially the HC 6030 meters can be used as stand-alone units. Open architecture allows connection to other ModBus® compatible system for over all process monitoring and control.

Option

8 status input : 8 status inputs with internal DC28V powered, can be configured to 8 status inputs (break condition) or to 7 counter inputs and one demand synchronized input.

4 analog output : 4 isolated analog outputs can be used to replace 4 or more analog transducers.

Output signals can be selected from any of the measured parameters.

- 3 analog inputs : 3 analog inputs for process variables (such as temperature. Water level or flow rate etc.) Can be monitored and used for control.
- 2 energy pulse outputs: 2 energy pulse outputs of WH and VarH can be used to energy management or used to replace energy transducer.
- 24 setpoints with 3 relay control output

Control

3 output relays / 8 switch inputs / measured parameters from the standard HC 6030 can be combined with setpoints and input / outputs for control applications. With the control option, 3 output relays and 8 switch inputs are added along with programmable setpoints. Output relays can also be controlled via the communication port or assigned to different setpoints for user programming to accommodate many situations. Possibilities include:

- Under current alarm for pumps
- Over / under voltage for generators
- Unbalance alarm for rotating machines
- Dual level power factor for capacitor bank switching
- Under frequency / demand output for load shedding resulting in power cost savings
- KWH, KVarH and KVAH pulse output for PLC interface
- Fault recorder for 3 voltages and 3 currents

Power analysis

Data logger (trending) : trending is useful as a troubleshooting aid when a problem is detected. Measured values can be selected and plotted with a programmable sampling rate to suit the time interval of interest. The generated chart recorder screen can be printed or exported to other programs for report writing.

Harmonic analysis: non linear loads such as variable speed drives, computers and electronic ballasts can cause harmonics which may lead to problems such as nuisance breaker tripping, telephone interference, transformer, capacitor or motor overheating. For fault diagnosis such as detecting undersized neutral wiring, need for a harmonic rated transformer, or effectiveness of harmonic filters, details of the harmonic spectrum are useful and available with the power analysis option.

- Waveform capture : voltage and current waveforms can be captured and displayed on a PC using the HC 6030 PC program supplied with the HC 6030 or using third party software. Distorted peaks or notches from SCR switching provide clues for taking corrective action.
- Event logger : alarms, setpoint triggers, input and output events can be stored in a 200 event record and time / date stamped by the internal clock. This is use full for diagnosing problems and system activity. Minimum and maximum values are also continuously up dated and time stamped.
- Trace memory : the HC 6030 can be configured to record 16 to 64 cycle of data length on all voltage and current input based on setpoint activation to under voltage, over voltage, over current or switch input state change and etc.

HC 6030 PC program

The PQM PC program is a Windows® based program for the HC 6030. It can be used to enter setpoints, read metered values, monitor status and evaluate power quality. All data continuously gathered by the HC 6030 can be transferred to a third party software program for display, control or analysis via the communications interface.

Once all setpoints have been entered they can be downloaded into any HC 6030 or stored in a file with a tag name for later reference.

Screens are available for monitoring all measured values such as current, voltage or power. Status of alarms and control settings can also be displayed.

Voltage and current wave shape can give important information about what is happening on a system. For example, non-linear loads such as computers or variable speed drives may introduce distortion that indicates filtering is required.

Harmonic analysis may reveal excessive harmonic content requiring a dreaded transformer or larger neutral wire. Early warning of these problems can prevent equipment damage or nuisance breaker tripping.

Model & Ordering Number

Model : HC 6030

Ordering : HC 6030 - A - 5.0A - H - 3 - N

Version

Current Input

1.0A

5.0A

Power

H : AC 80-260V, DC 80-330V

L : DC 20-60V

Option

N : No option

A : DC Analog output x 4

B : Pulse output x 2

C : Relay control output x 3

Alarm setpoint x 24

D : Status input x 8

E : DC Analog input x 3

F : Trigger to memory trace log

Communication Port

3 : RS-485 + RS-232

Y : Special Ordering

Specification

Measured power parameters

Param.	Accuracy	Phase1	Phase2	Phase3	Phase0	Total
VP x 3	0.15% fs	VP1	VP2	VP3		VPE
VL x 3	0.15% fs	VL1	VL2	VL3		VLE
A x 4	0.15% fs	A1	A2	A3	A0	
Watts	0.25% fs	W1	W2	W3		W
Vars	0.25% fs	Var1	Var2	Var3		Var
VA	0.25% fs	VA1	VA2	VA3		VA
PF	0.25% fs	PF1	PF2	PF3		PF
WH	0.8% rd					WH
VarH	1% rd					VarH
Hz	0.03% rd					
Phase Rotation						

Data memory

- > 1M bits
- Cell backup > 400000 hours continuous at power OFF

Data logger

- Waveform capture log
 - Sample rate 64 / Hz, length 2 cycle
 - Parameter / 3 voltages and 3 currents
- Trend logger
 - 20 parameters with time-stamped VP1, VP2, VP3, VPE, VL1, VL2, VL3, VLE, A1, A2, A3, A0, AE, W, Var, VA, PF, FQ, Vubl, Aubl
 - Sample rate 15 / 30 / 60 minute per sample
 - Length 960 datas / parameter
 - Length 10 days / 15 minutes, 40 days / 60 minutes
- Event logger
 - 200 events with time-stamped
 - Status change of switch input
 - Activation of setpoints / alarms
 - Operation of controlled relay output
 - Failure in communication to comport
 - Failure in self test
 - Programming access
 - Trace memory triggered
 - Power ON / OFF
- Control output
 - 3 assignable relay outputs
- Maximum / minimum logger
 - 20 parameters with time-stamped VP1, VP2, VP3, VPE, VL1, VL2, VL3, VLE, A1, A2, A3, A0, AE, W, Var, VA, PF, FQ, Vubl, Aubl
- Triggered trace memory / fault recording
 - Recorded 6 parameters of three phase voltages & currents
 - Triggered mode / retriggering
 - Sample rate 16 / Cycle
 - 4 buffers, 1 buffer for 32 cycles length

User programming

- Communication to baud rate and address.
 - Baud 1.2K / 2.4K / 4.8K / 9.6K / 19.2K bits
 - Address 1-254
- Measuring system to 3 phases 3 wires / 3 phase 4 wires / single phase 3 wires / single phase 2 wires
 - PT ratio 1.0-5000.0
 - CT ratio 1.0-2000.0
- Nominal frequency, 50 / 60Hz
- Display control
 - Manual / auto- scanning

- DI, input preset
 - DI1 - DI8 configurable
 - Switch status
 - Pulse input
 - Synchronized trigger to demand
- Analog output (A01 - A04)
- Analog input (AI1 - AI3)
- Preset pulse output, WH / QH
 - Preset LED indicator, WH / QH / AH / VAH
- 24 alarm setpoints with trigger parameter, dead band, time delay and operation to controlled relay output
- 3 assigned control relay output
- Reset to maximum / minimum log
- Trend log
- Triggered trace memory
- Time base correction
- Time of use with tariff to power energy (8 channels)

Dielectric strength

- IEC 255-5
- 2KV AC rms 1 minute between input / output / power

Impulse and surge test (EMC)

- ANSI C37.90.1-1989 (3KV) SWC test
- IEC 255-22-1 class III SWC test
- IEC 255-22-4 class IV (IEC 801-4) SWC test
- IEC 255-5 1.2 x 50us (5KV) impulse test

Operating condition

- Temperature range -25 to +60°C
- RH 20-95% non-condensed

Storage condition

- Temperature range -25 to +70°C
- RH 20-95% non-condensed

Power supply

- AC 80-260V, 40-70Hz, DC 80-330V
- DC 20-60V
- Dissipation maximum 8 watts

Dimension / mounting

- DIN 144 x 144 x 100mm, panel mount

Cut out

- 138⁺¹ x 138⁺¹mm

Wiring

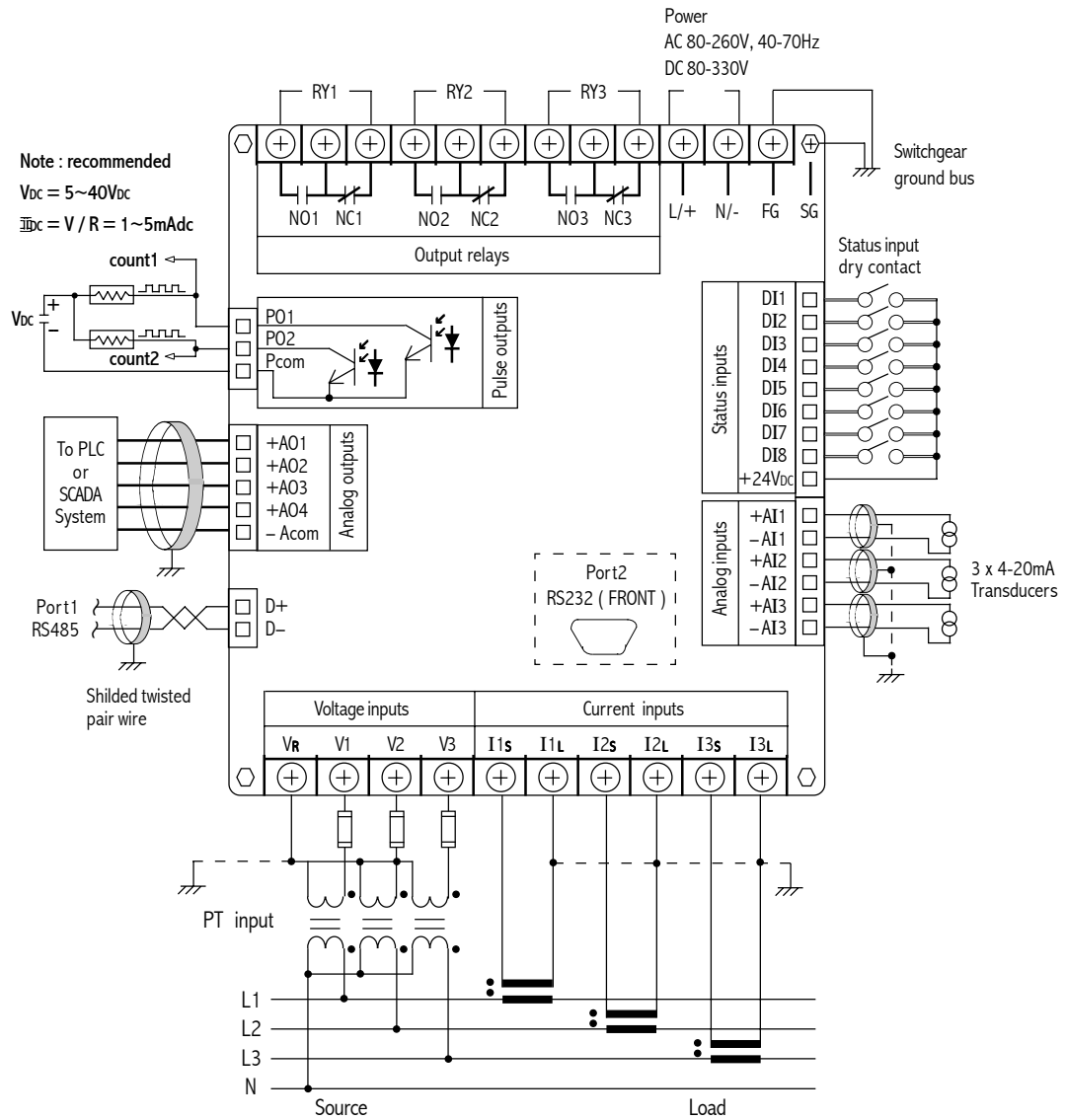

3 phase 4 wires WYE / 3VTs

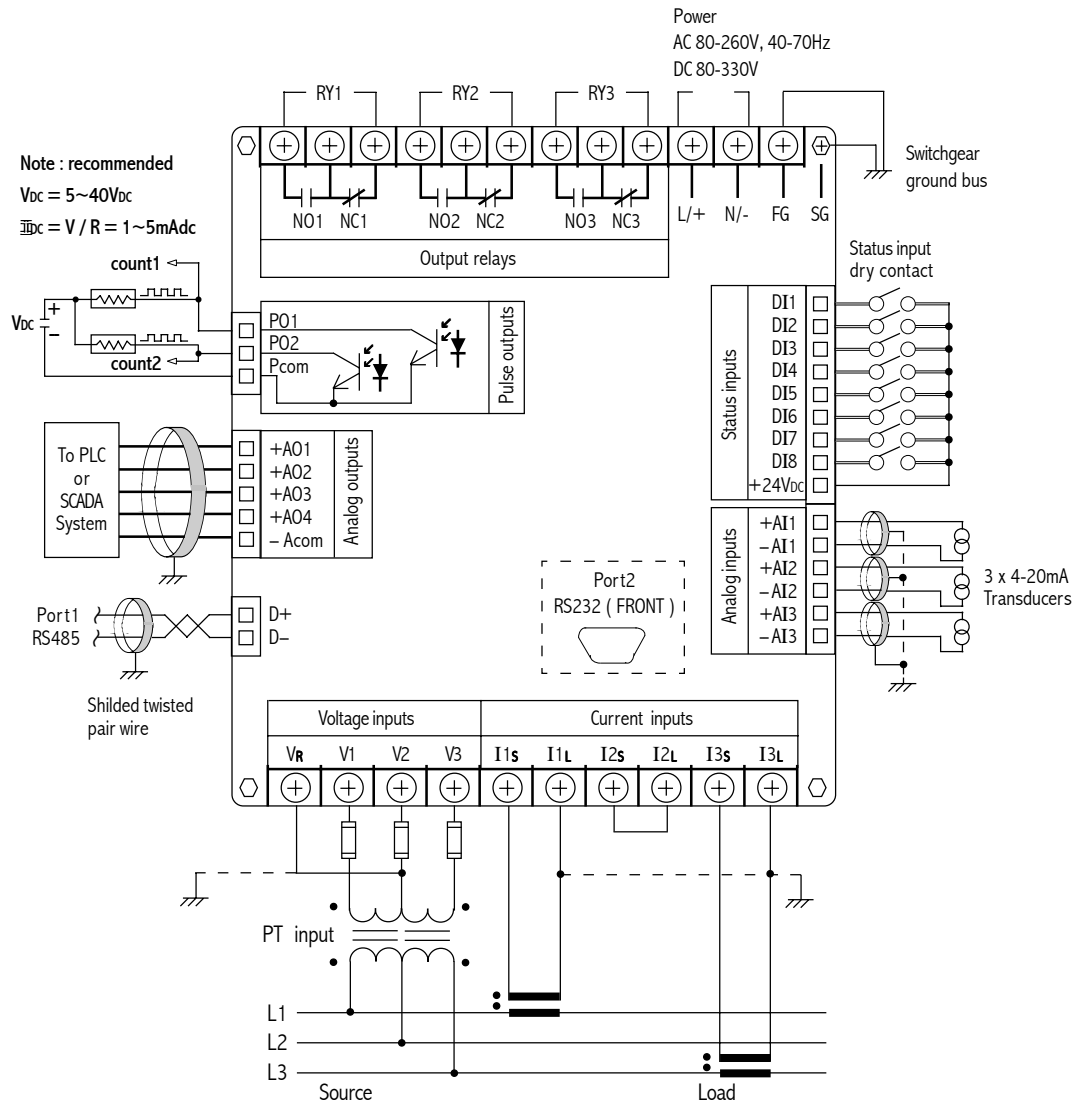

3 phase 3 wires DELTA / 2VTs

Dimension

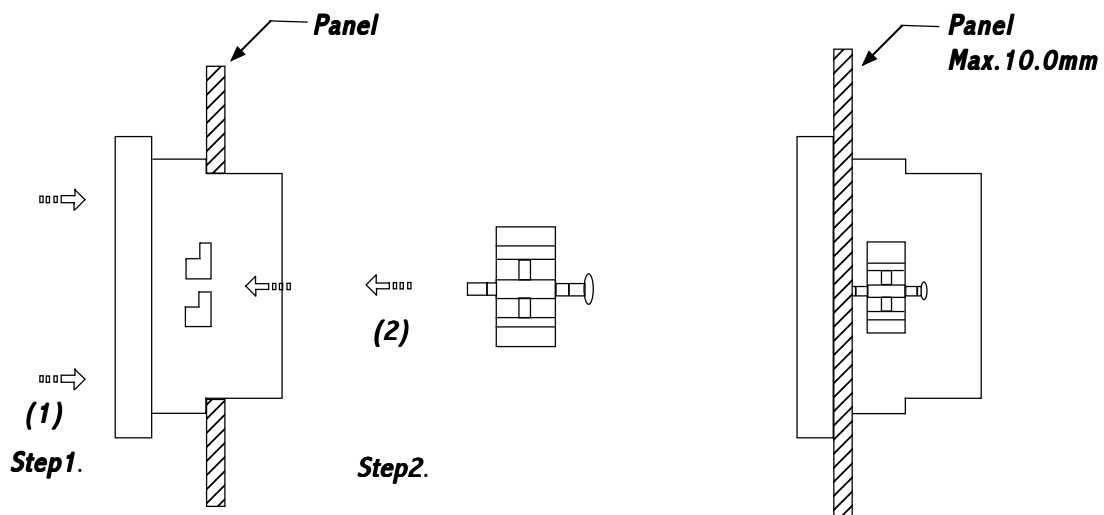
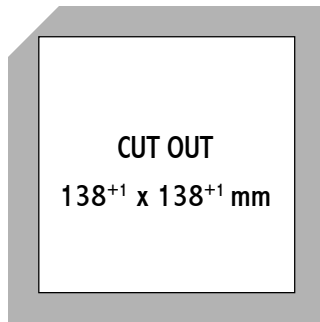
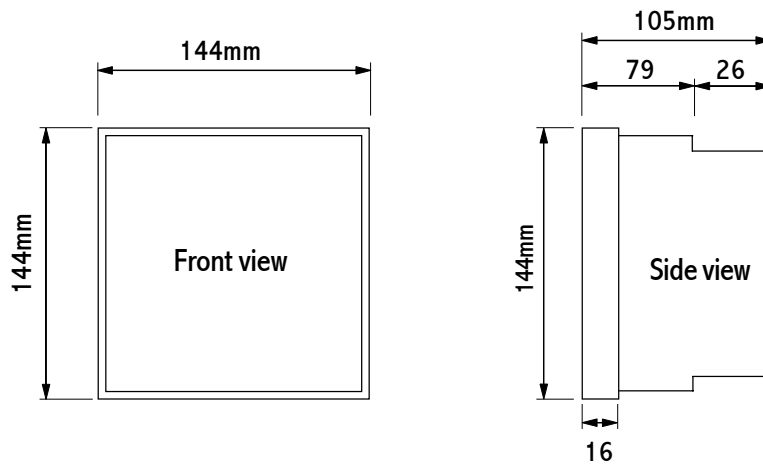

Applications

The HC 6030 PC TOOL a utility program that can help user to connect to “HC 6030 Power Quality Meter” rapidly. The HC 6030 PC TOOL is provided along with every HC 6030, which allows easy access to all meter setup information and actual values via a personal computer running Windows 95/98 and one of the PC’s communication ports (COM1 or COM2).

The PC TOOL is able to do the function as below:

- Program / Modify setup information
- Load / save setup information files from / to disk
- Read actual “Basic” value (current / voltage / power / frequency)
- Read actual “statistics” value (maximum / minimum / time of maximum / time of minimum)
- I/O control (AI / AO / DI / PO)

The HC 6030 PC TOOL can be used as stand-alone without a HC 6030 meter to create or edit HC 6030 setup information files.

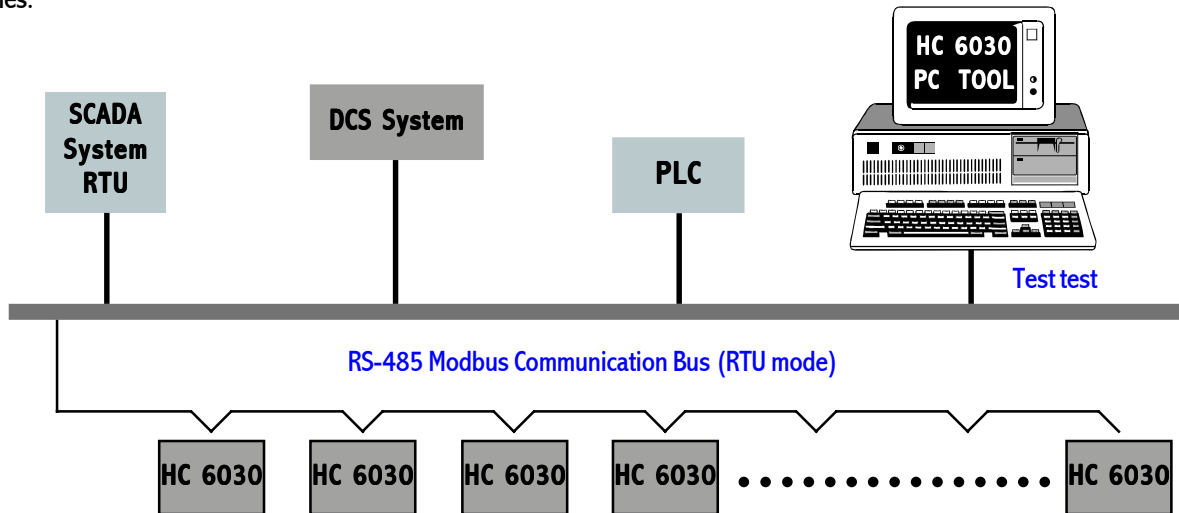

Communication Wiring

